

White Petrolatum

Stage 4, Revision 1

Definition

White Petrolatum is a purified and wholly or nearly decolorized semi-solid mixture of hydrocarbons obtained from petroleum. It may contain a suitable antioxidant.

Description and Solubility - White or faintly yellowish, unctuous mass, transparent in thin layers even after cooling to 0 °C. Insoluble in water; slightly soluble in cold or hot alcohol, and in cold dehydrated alcohol; freely soluble in benzene, in carbon disulfide, and in chloroform; soluble in ether, in solvent hexane, and in most fixed and volatile oils.

Packaging and storage - Preserve in well-closed containers, protected from light.

Labeling - Label it to indicate the name and proportion of any added antioxidant. Where the labeling indicates the consistency, determine compliance using *Consistency*.

Identification -

A. Infrared Absorption Spectrophotometry, obtained by spreading a thin film of melted test specimen between sodium chloride plates

B. Color - Melt about 10 g on a steam bath, and pour about 5 mL of the liquid into a clear-glass 15- × 150-mm test tube, keeping the White Petrolatum melted. The White Petrolatum is not darker than a mixture of Ferric Chloride Solution: 10 mg/mL hydrochloride acid (1:9) in a similar tube, the comparison of the two being made in reflected light against a white background, the White Petrolatum tube being held directly against the background at such an angle that there is no fluorescence.

C. Drop Point - Apparatus. The apparatus consists of 2 metal sheaths (*A* and *B*) screwed together. Sheath *A* is fixed to a mercury thermometer. A metal cup is loosely fixed to the lower part of sheath *B* by means of 2 tightening bands. Fixed supports 2 mm long determine the exact position of the cup, and in addition are used to centre the thermometer. A hole pierced in the wall of sheath *B* is used to balance the pressure. The draining surface of the cup must be flat and the edges of the outflow orifice must be at right angles to it. The lower part of the mercury thermometer has the form and size shown in the figure; it covers a range from 0 °C to 110 °C and on its scale a distance of 1 mm represents a difference of 1 °C. The mercury reservoir of the thermometer has a diameter of 3.5 ± 0.2 mm and a height of 6.0 ± 0.3 mm. The apparatus is placed in the axis of a test-tube about 200 mm long and with an external diameter of about 40 mm. It is fixed to the test-tube by means of a laterally grooved stopper through which the thermometer passes. The opening of the cup is placed about 15 mm from the bottom of the test-tube. The whole device is immersed in a beaker with a capacity of about 1 litre, filled with water. The bottom of the test-tube is placed about 25 mm from the bottom of the beaker. The water level reaches the upper part of sheath *A*. A stirrer is used to ensure that the temperature of the water remains uniform. Alternatively, an automated method can be used.

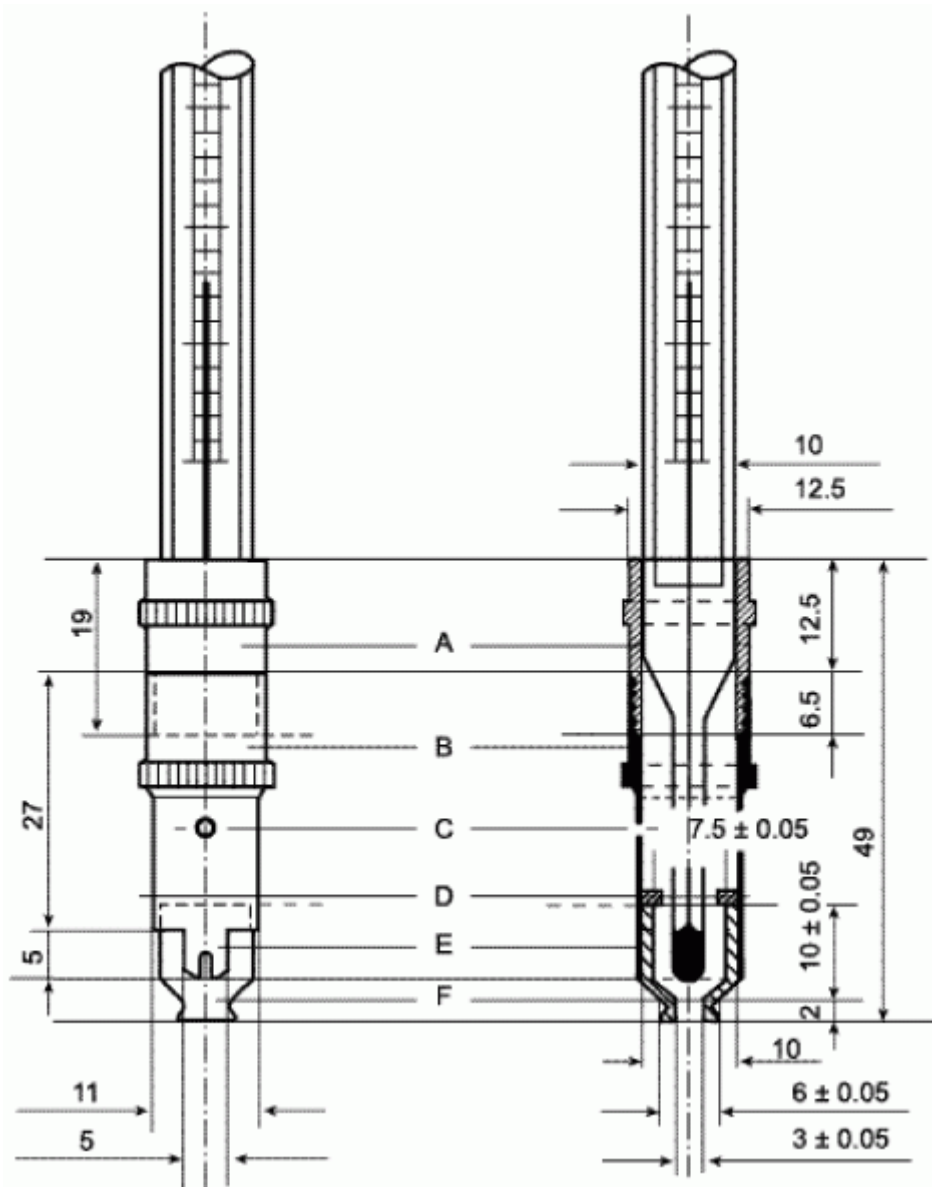

- | | |
|----------------------------|---------------------|
| A. upper metal sheath | D. fixed supports |
| B. lower metal sheath | E. tightening bands |
| C. pressure-balancing hole | F. metal sample cup |

Figure 1. Apparatus for the determination of drop point

Dimensions in millimeters

Heat the substance to be examined at 118-122 °C, with stirring to ensure uniformity. Warm the metal cup at 118-122 °C in an oven, remove it from the oven, place on a clean plate or ceramic tile and pour a sufficient quantity of the melted sample into the cup to fill it completely. Allow the filled

cup to cool for 30 min on the ceramic tile and place it in a water-bath at 24-26 °C for a further 30-40 min. Level the surface of the sample with a single stroke of a knife or razor blade, avoiding compression of the sample. Determine the drop point using a starting temperature of 35 °C and increasing the temperature at a rate of 1 °C/min.” Note the temperature at the fall of the first drop. Carry out at least 3 determinations, each time with a fresh sample of the substance. The difference between the readings must not exceed 3 °C. The mean of 3 readings is the drop point of the substance. The drop point is 35 °C to 70 °C and does not differ by more than 5 °C from the value stated on the label

Consistency - [Note: Where the labeling indicates the consistency, determine compliance using this test.]

Apparatus— Determine the consistency of White Petrolatum by means of a penetrometer fitted with a polished cone-shaped metal plunger weighing 150 g, having a detachable steel tip of the following dimensions: the tip of the cone has an angle of 30 °C, the point being truncated to a diameter of 0.381 ± 0.025 mm, the base of the tip is 8.38 ± 0.05 mm in diameter, and the length of the tip is 14.94 ± 0.05 mm. The remaining portion of the cone has an angle of 90 °C, is about 28 mm in height, and has a maximum diameter at the base of about 65 mm. The containers for the test are flat-bottom metal cylinders that are 100 ± 6 mm in diameter and not less than 65 mm in height. They are constructed of at least 1.6-mm (16-gauge) metal, and are provided with well-fitting, water-tight covers.

Procedure— Place the required number of containers in an oven, and bring them and a quantity of White Petrolatum to a temperature of 82 ± 2.5 °C, pour the White Petrolatum into one or more of the containers, filling to within 6 mm of the rim. Cool to 25 ± 2.5 °C over a period of not less than 16 hours, protected from drafts. Two hours before the test, place the containers in a water bath at 25 ± 0.5 °C. If the room temperature is below 23.5 °C or above 26.5 °C, adjust the temperature of the cone to 25 ± 0.5 °C by placing it in the water bath.

Without disturbing the surface of the substance under test, place the container on the penetrometer table, and lower the cone until the tip just touches the top surface of the test substance at a spot 25 mm to 38 mm from the edge of the container. Adjust the zero setting and quickly release the plunger, then hold it free for 5 seconds. Secure the plunger, and read the total penetration from the scale. Make three or more trials, each so spaced that there is no overlapping of the areas of penetration. Where the penetration exceeds 20 mm, use a separate container of the test substance for each trial. Read the penetration to the nearest 0.1 mm. Calculate the average of the three or more readings, and conduct further trials to a total of 10 if the individual results differ from the average by more than $\pm 3\%$: the final average of the trials is not less than 10.0 mm and not more than 30.0 mm, indicating a consistency value between 100 and 300.

Acidity or alkalinity - To 10 g add 20 mL of boiling water and shake vigorously for 1 min. Allow to cool and decant. To 10 mL of the aqueous layer add 0.1 mL of *phenolphthalein solution*. The solution is colorless. Not more than 0.5 mL of *0.01 M sodium hydroxide* is required to change the color of the indicator to pink or red.

Residue on ignition - Heat 2 g in an open porcelain or platinum dish over a Bunsen flame: it volatilizes and on ignition yields not more than 0.05% of residue.

Polycyclic aromatic hydrocarbons - maximum 300 ppm.

Dissolve 1.0 g in 50 ml of hexane which has been previously shaken twice with 10 ml of *dimethyl sulfoxide*. Transfer the Solution to a 125 ml separating funnel with unlubricated ground-glass parts (stopper, stopcock). Add 20 ml of *dimethyl sulfoxide*. Shake vigorously for 1 min and allow to stand until 2 clear layers are formed. Transfer the lower layer to a second separating funnel. Repeat the extraction with a further 20 ml of *dimethyl sulfoxide*. Shake vigorously the combined lower layers with 20 ml of *hexane* for 1 min. Allow to stand until 2 clear layers are formed. Separate the lower

layer and dilute to 50.0 ml with *dimethyl sulfoxide*. Measure the absorbance over the range 260 nm to 420 nm using a path length of 4 cm and as compensation liquid the clear lower layer obtained by vigorously shaking 10 ml of *dimethyl sulfoxide* with 25 ml of *hexane* for 1 min. Prepare a reference Solution in *dimethyl sulfoxide* containing 6.0 mg/L of *naphthalene* and measure the absorbance of the Solution at the maximum at 278 nm using a path length of 4 cm and *dimethyl sulfoxide* as compensation liquid. At no wavelength in the range 260 nm to 420 nm does the absorbance of the test Solution exceed that of the reference Solution at 278 nm.

REAGENTS

Ferric Chloride Solution (Yellow solution) - Dissolve about 55 g of Ferric Chloride ($\text{FeCl}_3 \cdot 6\text{H}_2\text{O}$) in enough of a mixture of 25 mL of hydrochloric acid and 975 mL of water to make 1000 mL. Pipet 10 mL of this solution into a 250-mL iodine flask, add 15 mL of water, 3 g of potassium iodide, and 5 mL of hydrochloric acid, and allow the mixture to stand for 15 minutes. Dilute with 100 mL of water, and titrate the liberated iodine with 0.1 N sodium thiosulfate VS, adding 3 mL of starch solution as the indicator. Perform a blank determination with the same quantities of the same reagents, and make any necessary correction. Each mL of 0.1 N sodium thiosulfate is equivalent to 27.03 mg of $\text{FeCl}_3 \cdot 6\text{H}_2\text{O}$. Adjust the final volume of the solution by the addition of enough of the mixture of hydrochloric acid and water so that each mL contains 45.0 mg of $\text{FeCl}_3 \cdot 6\text{H}_2\text{O}$.

Starch Solution - Mix 1 g of soluble starch with 10 mg of red mercuric iodide and sufficient cold water to make a thin paste. Add 200 mL of boiling water, and boil for 1 minute with continuous stirring. Cool, and use only the clear solution.

[NOTE1 - Commercially available, stabilized starch indicator solutions may be used.]

[NOTE 2 - Starch solution can be prepared without the use of red mercuric iodide, provided the solution is used immediately after preparation.]

Hydrogen Peroxide Solution - Contains, in each 100 mL, not less than 2.5 g and not more than 3.5 g of H₂O₂.

Phenolphthalein Solution - Dissolve 1 g of phenolphthalein in 100 mL of alcohol.

Methyl Orange Solution - Dissolve 100 mg of methyl orange in 100 mL of water, and filter if necessary.